

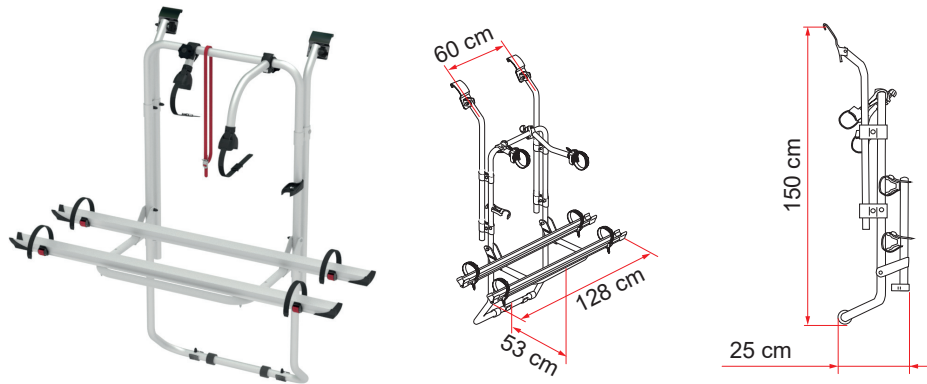

# Ford Transit

Designed for Ford Transit with single rear door (≥ 2000 ≤ 2011 - H1).



## GENERAL INFORMATION

- Carries up to 3 bicycles
- Delivered as standard with 2 Rail Quick Pro, 1 Bike-Block Pro 1 and 1 Bike-Block Pro 3
- The tailgate can be opened with the Carry-Bike mounted without bikes
- Ford Transit MK3-MK4-MK5-MK6-MK7 (≥2000 ≤ 2011 - H1)

## TECHNICAL FEATURES

- Weight: 8,2kg
- Maximum loading weight: 50kg
- Distance between rails: 15cm



## INSTALLATION OF THE ADDITIONAL RAILS

The diagram suggests the combination between additional Bike-Block and Rail to safely transport up to 3 bikes



Description	Item No.	EAN code	Third bike	
			Bike-Block	Rail
Ford Transit	02093A60A	8004815378844	04133A01A	98656-993

Description	Weight	Max load	Bikes standard	E-Bike
Ford Transit	7,1kg	50kg	2 / 3	-

## ACCESSORIES

- Bike-Block Pro
- Bike-Block Pro S
- Bike-Block Pro S D
- Rail Quick Pro
- Rail Premium / S
- Rail Plus
- Bike Frame Adapter
- Cable-Lock
- Licence Plate Carrier
- Alu Signal
- Plastic Signal



Installation

